

Autonics

LIQUID LEVEL SENSOR BL SERIES

INSTRUCTION MANUAL



Thank you for choosing our Autonics product.
Please read the following safety considerations before use

■ Safety Considerations

※ Please observe all safety considerations for safe and proper product operation to avoid hazards.
※ ⚠ symbol represents caution due to special circumstances in which hazards may occur.

- ⚠ **Warning** Failure to follow these instructions may result in serious injury or death.
- ⚠ **Caution** Failure to follow these instructions may result in personal injury or product damage.

⚠ Warning

1. **Fail-safe device must be installed when using the unit with machinery that may cause serious injury or substantial economic loss.** (e.g. nuclear power control, medical equipment, ships, vehicles, railways, aircraft, combustion apparatus, safety equipment, crime/disaster prevention devices, etc.)
Failure to follow this instruction may result in personal injury, economic loss or fire.
2. **Do not use the unit in the place where flammable/explosive/corrosive gas, high humidity, direct sunlight, radiant heat, vibration, impact, or salinity may be present.**
Failure to follow this instruction may result in explosion or fire.
3. **Do not disassemble or modify the unit.**
Failure to follow this instruction may result in fire.
4. **Do not connect, repair, or inspect the unit while connected to a power source.**
Failure to follow this instruction may result in fire.
5. **Check 'Connections' before wiring.**
Failure to follow this instruction may result in fire.

⚠ Caution

1. **Use the unit within the rated specifications.**
Failure to follow this instruction may result in fire or product damage.
2. **Use dry cloth to clean the unit, and do not use water or organic solvent.**
Failure to follow this instruction may result in fire.

■ Model

Model	Pipe diameter	Sensing type	Power supply	Control output
BL13-TDT	Ø6 to 13mm	Through-beam	12-24VDC ±10%	NPN open collector output
BL13-TDT-P	Ø6 to 13mm	Through-beam	12-24VDC ±10%	PNP open collector output

■ Dimensions

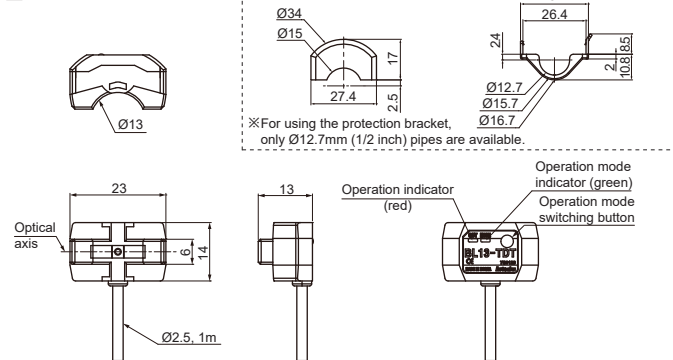

※ The above specifications are subject to change and some models may be discontinued without notice.
※ Be sure to follow cautions written in the instruction manual and the technical descriptions (catalog, homepage).

■ Specifications

Model	NPN open collector output PNP open collector output	BL13-TDT BL13-TDT-P
Sensing type	Through-beam	
Applicable pipe	●Using binding band: Ø6 to 13mm, ●Using protection bracket: Ø12.7mm (1/2 inch) transparent pipes in 1mm thickness (FEP (fluoroplastic) or with equivalent transparency)	
Standard sensing target	Liquid in a pipe※1	
Response time	Max. 2ms	
Power supply	12-24VDC ±10% (ripple P-P: max. 10%)	
Current consumption	Max. 30mA	
Light source	Infrared LED (950nm)	
Operation mode	Light ON/Dark ON switching by operation mode switching button	
Control output	NPN or PNP open collector output ●Load voltage: max. 30VDC ±5% ●Load current: max. 100mA ●Residual voltage: max. 1VDC ±5%	
Protection circuit	Reverse polarity protection circuit, output short over current protection circuit	
Indicator	Operation indicator: red LED, Operation mode indicator: green LED	
Insulation resistance	Over 20MΩ (at 500VDC megger)	
Noise immunity	±240V the square wave noise (pulse width: 1µs) by the noise simulator	
Dielectric strength	1,000VAC 50/60Hz for 1 minute (between all terminals and case)	
Vibration	1.5mm amplitude at frequency of 10 to 55Hz in each X, Y, Z direction for 2 hours	
Shock	500m/s ² (approx. 50G) in each X, Y, Z direction for 3 times	
Environment	Ambient illumination: Sunlight/Incandescent lamp: max. 3,000lx for each (receiver illumination) Ambient temperature: 10 to 55°C, storage: -25 to 65°C Ambient humidity: 35 to 85%RH, storage: 35 to 85%RH	
Protection structure	IP64 (IEC standard)	
Material	Case: Polycarbonate	
Cable	Ø2.5mm, 3-wire, 1m (AWG28, Core diameter: 0.08mm, Number of cores: 19, Insulator diameter: Ø0.9mm)	
Accessory	Binding band: 2, Anti-slip tube: 2	
Approval	CE	
Weight※2	Approx. 50g (approx. 13g)	

※1: This may not detect the liquid with low transparent, with high viscosity, or with floating matters.
※2: The weight includes packaging. The weight in parenthesis is for unit only.
※The temperature or humidity mentioned in Environment indicates a non freezing or condensation environment.

■ Connections

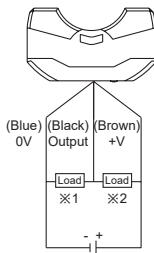

※1: Load connection for PNP output
※2: Load connection for NPN output

■ Control Output Circuit Diagram

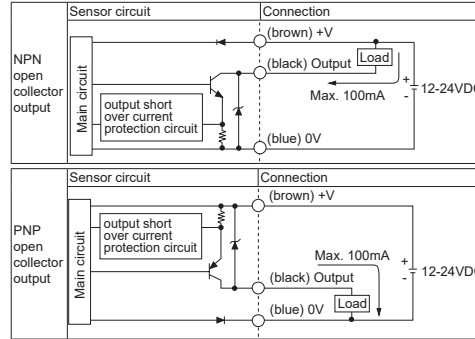

※If short-circuit the control output terminal or supply current over the rated specification, normal control signal is not output due to the output short over current protection circuit.

■ Installation

If installing this unit at opaque pipes, it is impossible to detect accurately. Install this unit at the rated pipes. Using binding band: Ø6 to 13mm, Using protection bracket: Ø12.7mm (1/2 inch)

●Binding band

Fix the pipe and the sensor tightly with binding bands and anti-slip tubes as the right figure and cut the spare part of binding bands with scissors or a knife.
When connecting binding bands, be careful not to transform the pipe.

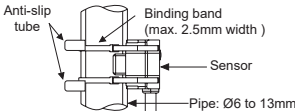

※Be sure that if there is water drop or bubble inner/outer wall of the pipe, it may result in malfunction.
※Do not pull the cable with a tensile strength of 30N or over. It may result in fire due to the broken wire.
※When using photoelectric sensors closely over two units, it may result in malfunction due to mutual interference.

●Protection bracket (sold separately)

Choose a location on the pipe and attach the sensor and the protection bracket.

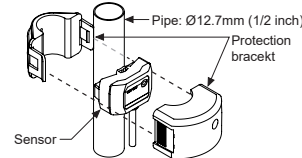

■ Functions

●Operation mode switching

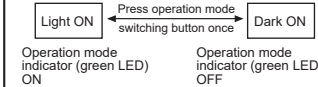

Operation mode indicator (green LED) ON

●Operation mode lock setting

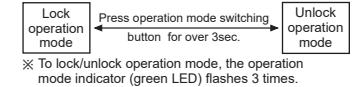

※ To lock/unlock operation mode, the operation mode indicator (green LED) flashes 3 times.

■ Operation Mode

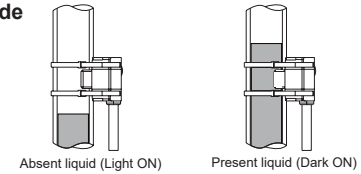

Operation mode	Light ON	Operation mode	Dark ON
Receiver operation	Received light Interrupted light	Receiver operation	Received light Interrupted light
Operation indicator (red LED)	ON OFF	Operation indicator (red LED)	ON OFF
Transistor output	ON OFF	Transistor output	ON OFF

■ Operating Timing Diagram

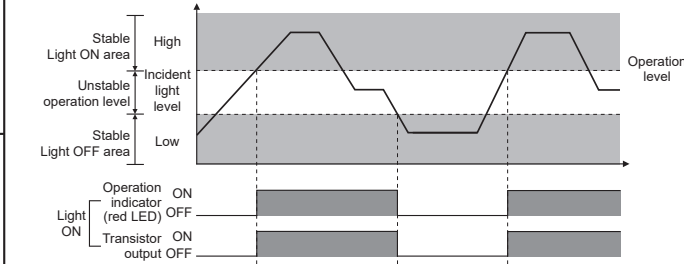

※ The waveforms of "Operation Indicator" and "Transistor Output" are for Light ON operation. They are reversed for Dark ON operation.

■ Cautions during Use

1. Follow instructions in 'Cautions during Use'. Otherwise, it may cause unexpected accidents.
2. When connecting a DC relay or other inductive load to the output, remove surge by using diodes or varistors.
3. Use the product, 0.2 sec after supplying power.
When using separate power supply for the sensor and load, supply power to sensor first.
4. 12-24VDC power supply should be insulated and limited voltage/current or Class 2, SELV power supply device.
5. Wire as short as possible and keep away from high voltage lines or power lines, to prevent inductive noise.
6. When using switching mode power supply to supply the power, ground F.G. terminal and connect a condenser between 0V and F.G. terminal to remove noise.
7. When using sensor with the equipment which generates noise (switching regulator, inverter, servo motor, etc.), ground F.G. terminal of the equipment.
8. This unit may be used in the following environments.
 - ① Indoors (in the environment condition rated in 'Specifications')
 - ② Altitude max. 2,000m
 - ③ Pollution degree 3
 - ④ Installation category II

■ Major Products

- Photoelectric Sensors
- Fiber Optic Sensors
- Door Sensors
- Door Side Sensors
- Area Sensors
- Proximity Sensors
- Pressure Sensors
- Rotary Encoders
- Connectors/sockets
- Switching Mode Power Supplies
- Control Switches/Lamps/Buzzers
- I/O Terminal Blocks & Cables
- Stepper Motors/Drivers/Motion Controllers
- Graphic/Logic Panels
- Field Network Devices
- Laser Marking System (Fiber, CO₂, Nd: YAG)
- Laser Welding/Cutting System
- Temperature Controllers
- Temperature/Humidity Transducers
- SSRs/Power Controllers
- Counters
- Timers
- Panel Meters
- Tachometer/Pulse (Rate) Meters
- Display Units
- Sensor Controllers

Autonics Corporation
http://www.autonics.com

■ HEADQUARTERS:
18, Bansong-ro 513 beon-gil, Haeundae-gu, Busan, South Korea, 48002
TEL: 82-51-519-3232
■ E-mail: sales@autonics.com